

### Durable Network Performance with High-End Features

- Fast 20 pages-per-minute laser output
- Duplex versatility — two-sided copying, printing, faxing, and color scanning
- PCL 5e/6 language support
- Built-in Ethernet port for printing and PC faxing
- 33.6 Kbps Super G3 fax with up to 1,000 pages of reception memory<sup>1</sup>
- 2 x 250-sheet cassettes plus 100-sheet multipurpose tray
- Legal-size platen and 50-sheet Automatic Document Feeder<sup>2</sup>
- Single Cartridge System
- Scan in color up to 600 dpi
- USB 2.0 Hi-Speed<sup>3</sup> for optimal performance



### Product Specifications

#### COPIER SPECIFICATIONS

**Duplex Copy/Bind Type**

1 to 1, 2 to 1, 2 to 2/Book, Calendar

**Copier Type**

Monochrome Laser

**Copy Speed**

Up to 20 cpm (letter)

**Copy Resolution**

600 x 600 dpi, 1200 x 1200 dpi quality

**Halftones**

256 levels

**Warm-up Time**

Less than 25 seconds

**First Copy Time**

Less than 8 seconds

**Paper Source(s)**

2 x 250-sheet cassettes plus 100-sheet multipurpose tray

**Paper Weight**

18 to 24 lb. (cassette), 18 to 32 lb. (multipurpose tray)

**Paper Output**

250 sheets (face down)

**Reduction/Enlargement**

50%, 64%, 73%, 78% / 121%, 129%, 200%

**Zoom**

50 - 200% in 1% increments

**Document Feeder**

50-sheet<sup>1</sup>

**Copy Size**

Platen: Up to 11.75" x 17"; ADF: Up to 11" x 17"

**Copy Features**

2, 4 in 1

**Copy Memory**

256MB (Shared)

#### PRINTER SPECIFICATIONS

**Duplex Print**

Yes

**Printer Type**

Monochrome Laser

**Print Speed**

Up to 20 ppm (letter)

**Print Resolution**

600 x 600 dpi; 1200 x 1200 dpi quality

**Print Language(s)**

PCL 5e/6, UFR IILT (Host-Based)

**Print Memory**

256MB (Shared)

**System Memory (On Board)**

256MB (Shared)

#### SEND SPECIFICATIONS

**Duplex Scan**

Yes

**Scanner Type**

Color Contact Image Sensor (CIS)

**Scan Resolution**

600 x 600 dpi

**Color Depth**

24-bit

**Document Size**

Platen: Up to 11" x 17"; ADF: Up to 11" x 17"

**Output File Formats**

Black and White: TIFF/PDF  
Color: JPEG/PDF Compact

#### FAX/PC FAX SPECIFICATIONS

**Duplex Fax**

Yes (transmission/reception)

**Modem Speed**

Up to 33.6 Kbps (Super G3)

**Fax Resolution**

Up to 400 x 400 dpi

**Memory Capacity**

More than 1,000 pages<sup>2</sup>

**Speed Dials**

200 one-touch / 300 coded dials

**Receive Modes**

Fax only, Manual, Answering

**Fax Features**

Remote RX, Relay, Delayed TX, Dual Access

**Memory Backup**

Yes (1 hour)

#### INTERFACE/SOFTWARE

**Standard Interface(s)**

USB 2.0 Hi-Speed<sup>3</sup>, Internal Ethernet (10/100 Base T)

**Network Function(s)**

Print, PC Fax and Scan

**Bundled Software**

Canon Printer Driver, Remote UI, NetSPOT Device Installer, NetSPOT Console

**OS Compatibility**

Windows® 98, Me, NT, 2000, XP, 2003 Server

#### GENERAL SPECIFICATIONS

**Dimensions**

24.5"(W) x 26.6"(D) 29.8"(H)

**Weight**

128 lbs.

**Power Consumption**

1.6kW (max)

**Replacement Consumable**

Canon Cartridge 105

**Warranty**

1 year limited warranty with on-site service<sup>4</sup>

<sup>1</sup> Based on 20 lb. paper.

<sup>2</sup> Based on ITU-T #1 Chart (standard mode).

<sup>3</sup> USB 2.0 Hi-Speed performance requires Windows®XP Service Pack 1 or Windows®2000 Service Pack 4 with pre-installed USB 2.0 port.

<sup>4</sup> Warranty program is subject to certain conditions and restrictions. See the warranty card for full details.

Features and specifications are subject to change without notice.



# imageCLASS® MF7280

## Duplex Copier | Laser Printer | Color Scanner Super G3 Fax | Network Capabilities

### Ordering Information

MODEL NO.	DESCRIPTION	ITEM NO.	UPC CODE
imageCLASS MF7280	Duplex Copier   Laser Printer Color Scanner   Super G3 Fax Network Capabilities	0785B001BA	0 13803 05612 9

### ACCESSORIES

Cartridge 105 (yields 10,000 pages based on 5% coverage)	Toner Cartridge	0265B001AA	0 13803 05715 7
imageCLASS 7200 Cabinet	Cabinet	5709A006AA	7 50845 82795 8

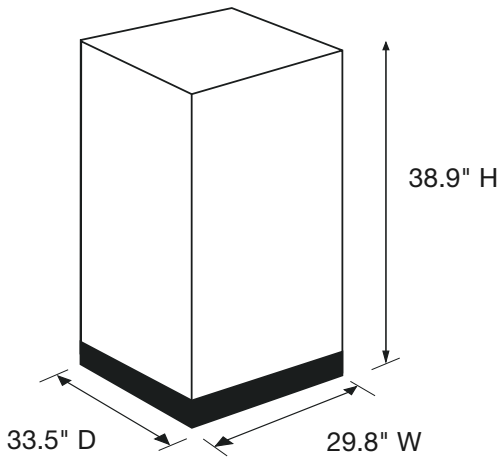

1 box per pallet

### Pallet Information

#### ORIGIN

Country of origin ..... China

#### PRODUCT INFORMATION

Individual unit dimensions (w/attachments) .....24.5"(W) x 26.6"(D) 29.8"(H)

Weight of individual box (pallet and box)\* .....160 lbs.

Weight of individual unit (w/attachments) .....128 lbs.

#### PALLET INFORMATION

Number of boxes per pallet .....1

Pallet dimensions (pallet and box)\* .....29.8"(W) x 33.5"(D) x 38.9"(H)

Pallet weight (pallet and box)\* .....160 lbs.

#### DATES

Availability ..... May 2006

\* Pallet and box are attached, not two separate units.



©2006 Canon U.S.A., Inc. Canon and imageCLASS are registered trademarks of Canon Inc. The Super G3 logo is a trademark of Canon Inc. IMAGEANYWARE is a trademark of Canon U.S.A., Inc. Microsoft, Windows, the Windows logo and Windows NT are either trademarks or registered trademarks of Microsoft Corporation in the United States and/or other countries. All other product and brand names are trademarks of their respective owners. Specifications are subject to change without notice. As an ENERGY STAR partner, Canon U.S.A., Inc. has determined that this product meets the ENERGY STAR guidelines for energy efficiency. The limited warranty given by Canon U.S.A., Inc. is for Canon imageCLASS MF7280 Series model purchased and used in the United States.